

RENOLD

escalator



RENOLD
step up to quality

Unique Quality and Safety

LEADING EDGE TECHNOLOGY

Renold provides practical cost effective solutions, with a commitment of value through quality. This is achieved by continuous investment in people, process technology and manufacturing.



CONSISTANT RELIABILITY

Renold's 100 years of experience in the design and manufacture of power transmission products, to the highest specifications, with proven performance in diverse industries worldwide, underwrites the guaranteed quality and the assurance of reliability.

Original patent drawing 1880 for bush roller chain

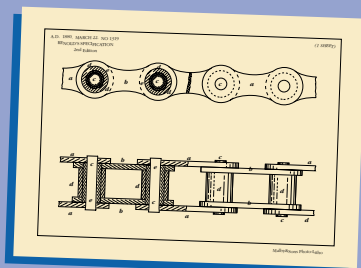

PACKAGE SOLUTIONS

One stop for your drive systems, including roller and conveyor chain, gears, motors, couplings, variators and fabricated bases.

SERVICE EXCELLENCE AND CARE

Renold offers a unique level of service excellence and customer care. Our experienced applications engineers will select the optimum solution with the aid of the latest computer and design technology. Renold is the name for service, care and peace of mind.

SPECIAL SOLUTIONS AND INNOVATIONS

Renold is recognised throughout the industry for its capability to create specific solutions to customers' unique requirements. International companies and industries from steel to food processing to escalators to textile machinery have chosen Renold to solve their problems.

LOCAL AND INTERNATIONAL AVAILABILITY

The Renold organisation stretches world-wide.

- 17 National Sales Companies
- Over 70 Overseas Distributors offering the comprehensive Renold range of power transmission products, directly or through local distributor networks.

APPROVALS AND QUALITY ASSURANCE

Renold's chain factories have ISO 9001:2000 certification. The roller chain manufacturing sites also have ISO 14001:1996 certification. The gear, clutch and couplings sites all have ISO 9001:1994 certification.



We also manufacture to the specifications required by API, BAe, CAA, LONDON UNDERGROUND, ROLLS-ROYCE and JAGUAR.

RENOLD ESCALATOR SOLUTIONS

To meet the demands of major escalator users such as Metro system operators, Renold's special experience in providing value engineered design solutions for public service escalators utilises modern materials and the very latest lubrication techniques. Renold has designed and manufactured high performance escalator systems for more than 50 years. Renold supplies escalator manufacturers and end users with roller chain, step chain, individual drive units and drive packages that surpass the high standards required for this safety conscious industry.

PRODUCT RANGE

- An extensive range of step chains is available to meet the specific requirements of manufacturers, service companies and operators. Drive packages include wormgear units and helical gear units customised with motor, brake and clutch additions to provide the optimum drive solutions.

RENOLUBE

- A range of self-lubricating and low maintenance chains can be supplied for most replacement or original applications. This range is branded Renolube. (See page 7, for further information)

REPUTATION

- Internationally, Renold have established an unrivalled expertise for supplying products for escalators made by many of the world's leading manufacturers, including: APV, Fiam, J&E Hall, KONE, Montgomery, O&K, Otis, Schindler and Thyssen.

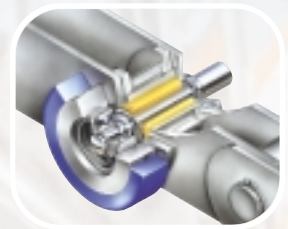
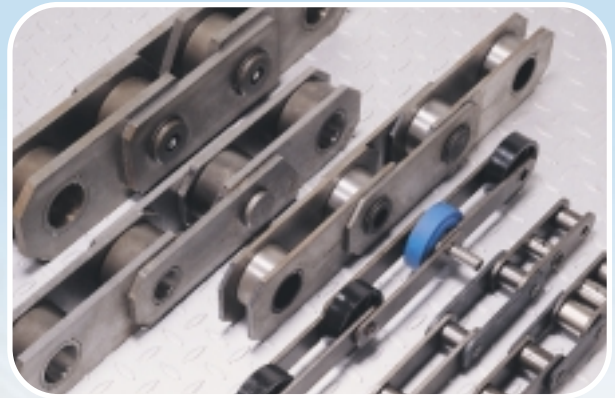

Escalator Industry - Step Chains

ENGINEERED CHAINS

Renold Chain's philosophy is to develop a close working partnership with escalator designers and operational engineers, to provide the most value engineered chain solution for new and existing escalators.

By understanding the operating requirements and environment for specific escalator applications, using the experience gained over 50 years of step chain manufacture, Renold have designed a comprehensive range of chains to meet the needs and demands of manufacturers and users worldwide.

A selection of popular chain types is listed, and includes heavy duty chains used on public service escalators and conveyors in transport systems.

There are many small variations in escalator chain dimensions, and the information in the following tables should be used as a guide only. Confirmation of design detail will be required prior to ordering. Please contact Renold Chain to discuss any requirements for escalator chain.

E 200 SERIES

Step fixing extended pin. Illustration shows polymer inboard rollers, other types may have steel rollers. E 200 Series chains are typically used on store type escalators, as manufactured by CNIM, J & E Hall, Kone, Montgomery, O & K, Otis, Schindler and Thyssen.

STORES TYPE

Nominal Dimensions (mm)

| Series | Pitch (mm) A | Inside Width (mm) B | Roller Dia. (mm) C | Pin Dia. (nominal) D | Inner Plate height E | Inner Plate thick F | Outer Plate height G | Outer Plate thick H | Breaking Load (kN) | Types |
|--------|-----------------|------------------------|-----------------------|--|-------------------------|------------------------|-------------------------|------------------------|--------------------|----------------|
| E 201 | 101.25 | 27.40 | 75.00 | 14.62 | 35.00 | 5.95 | 35.00 | 6.00 | 122 | Thyssen 68 |
| E 202 | 101.24 | 24.13 | 28.01 | 14.28 | 38.85 | 6.35 | 37.99 | 6.29 | 182 | Montgomery |
| E 203 | 133.33 | 25.09 | 75.00 | 14.62 | 32.50 | 5.05 | 32.50 | 5.05 | 128 | O & K |
| E 204 | 101.25 | 25.00 | 28.00 | 14.60 | 38.85 | 6.35 | 35.00 | 5.95 | 120 | J & E Hall (V) |
| E 205 | 101.25 | 25.40 | 25.38 | 14.62 | 35.00 | 5.95 | 35.00 | 4.95 | 122 | Thyssen 57 |
| E 206 | 133.35 | 27.40 | 70.00 | 14.62 | 40.00 | 4.95 | 40.00 | 4.95 | 114 | Schindler |
| E 207 | 133.33 | 20.20 | 75.00 | 12.46 | 32.00 | 5.05 | 32.00 | 5.05 | 98 | O & K |
| E 211 | 101.25 | 25.25 | 28.00 | 14.62 | 35.00 | 5.95 | 35.00 | 5.95 | 120 | Thyssen |
| E 212 | 133.35 | 27.40 | 70.00 | 14.62 | 40.00 | 4.95 | 40.00 | 4.95 | 114 | Schindler |
| E 213 | 133.33 | 27.40 | 70.00 | 14.62 | 40.00 | 5.00 | 40.00 | 5.00 | 114 | Schindler |
| E 214 | 44.45 | 25.23 | 25.40 | based on ANSI 140 with step pin at 15.75 | | | | | 191 | J & E Hall (U) |

STANDARD CHAINS - STORES TYPE

A range of chain is available for popular standard escalators operating in the retail sector, stores, shopping malls and buildings. See E 200 / E 300 / E 400 Series.

HEAVY DUTY / METRO REPLACEMENT

A range of chain is available for existing escalators in public service systems. We offer direct replacement to OEM specifications or equivalents. See E 500 / E 600 Series.

TRANSMISSION DRIVE CHAIN

- Renold provide an extensive range of chains for auxiliary drives on escalators such as Headshaft drive chain and Handrail drive chains. Chains are made to international standards: ISO606A and B / ANSI B29.1M / BS 228.
- Renold special chains are produced to existing manufacturers designs.

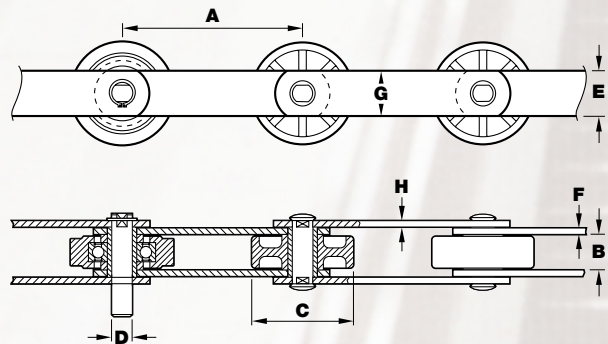

E 300 SERIES

Store type escalators with hollow bush step axle fixing.

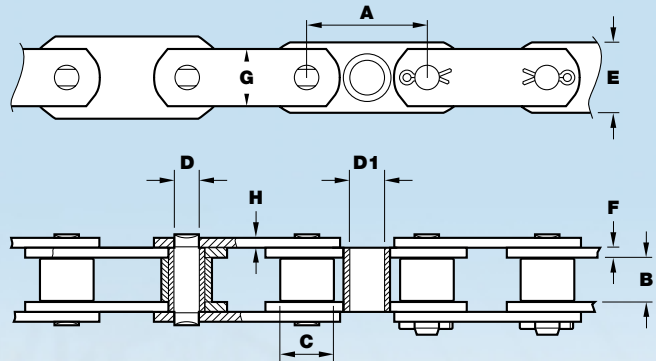

BUSH TYPE

Nominal Dimensions (mm)

| Series | Pitch (mm) A | Inside width (mm) B | Roller Dia. (mm) C | Pin Dia. (nominal) D | Step Bush Bore D1 | Inner Plate height E | thick F | Outer Plate height G | thick H | Breaking Load (kN) | Types |
|--------|--------------------|---------------------------|--------------------------|----------------------------|-------------------------|----------------------------|------------|----------------------------|------------|--------------------------|-------|
| E 301 | 100.00 | 25.40 | 25.40 | 12.67 | 15.13 | 37.10 | 5.50 | 37.10 | 5.50 | 186 | Fiam |
| E 302 | 67.74 | 30.98 | 28.01 | 14.24 | 22.07 | 38.36 | 4.92 | 32.00 | 4.92 | 137 | Otis |
| E 303 | 67.74 | 25.40 | 28.01 | 14.24 | 22.07 | 38.36 | 4.92 | 32.00 | 4.92 | 137 | Otis |
| E 304 | 68.40 | 20.50 | 31.95 | 14.29 | 23.62 | 38.85 | 4.90 | 32.00 | 4.90 | 140 | - |
| E 305 | 66.80 | 25.25 | 27.95 | 14.00 | 22.15 | 38.85 | 4.90 | 32.00 | 4.90 | 140 | Otis |

E 400 SERIES

Ladder / axle assembly chains supplied for use on light medium duty store type escalators.

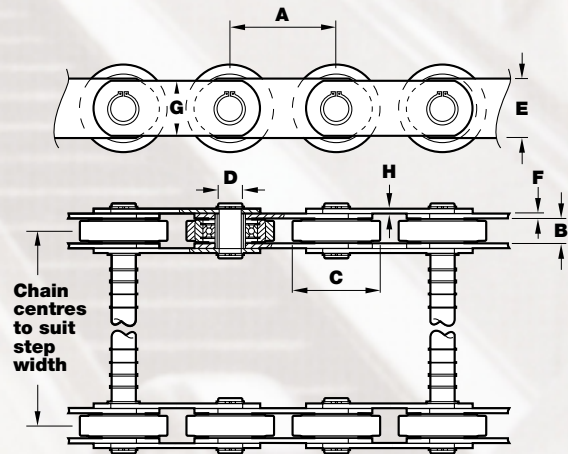

LADDER TYPE

Nominal Dimensions (mm)

| Series | Pitch (mm) A | Inside width (mm) B | Roller Dia. (mm) C | Pin Dia. (nominal) D | Inner Plate height E | thick F | Outer Plate height G | thick H | Breaking Load (kN) |
|--------|--------------------|---------------------------|--------------------------|----------------------------|----------------------------|------------|----------------------------|------------|--------------------------|
| E 401 | 135.46 | 31.87 | 39.95 | 20.10 | 45.25 | 5.02 | 45.25 | 5.02 | 220 |
| E 404 | 135.46 | 23.65 | 106.20 | 32.00 | 69.50 | 5.00 | 69.50 | 4.00 | 170 |
| E 405 | 135.46 | 23.92 | 75.95 | 12.60 | 38.05 | 4.62 | 31.75 | 4.68 | 102 |
| E 408 | 135.46 | 23.15 | 75.95 | 12.60 | 38.05 | 4.68 | 31.75 | 4.68 | 102 |
| E 409 | 135.46 | 23.95 | 76.00 | 15.10 | 40.00 | 4.97 | 31.75 | 4.69 | 100 |
| E 410 | 135.46 | 30.60 | 65.85 | 29.99 | 74.00 | 6.00 | 68.25 | 6.00 | 282 |
| E 411 | 135.46 | 25.20 | 76.00 | 19.99 | 45.25 | 6.00 | 45.25 | 6.00 | 148 |
| E 412 | 135.46 | 41.98 | 70.10 | 39.99 | 90.50 | 6.05 | 80.50 | 6.05 | 292 |
| E 413 | 135.46 | 32.10 | 40.05 | 20.12 | 45.00 | 4.95 | 40.00 | 4.95 | 123 |
| E 414 | 135.46 | 23.25 | 101.35 | 21.99 | 57.15 | 4.75 | 50.18 | 4.75 | 156 |
| E 415 | 135.46 | 30.82 | 65.85 | 29.99 | 74.00 | 6.00 | 68.25 | 5.70 | 250 |
| E 416 | 135.46 | 30.82 | 65.85 | 29.99 | 74.00 | 6.00 | 68.25 | 5.70 | 250 |

Escalator Industry - E Series

E 500 SERIES

Heavy duty, public service escalators for Metro / transit systems, airport and railways.

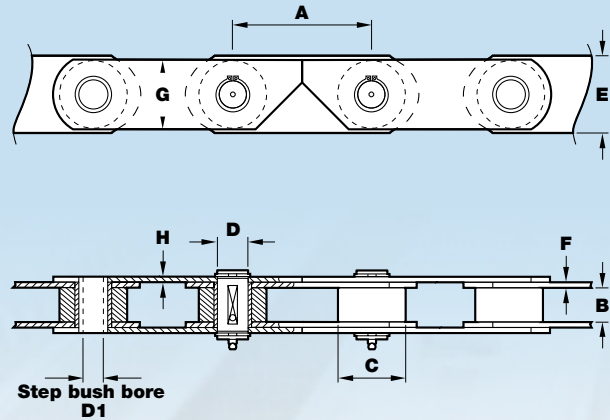

HEAVY DUTY TYPE Nominal Dimensions (mm)

| Series E 500 | Pitch (mm) A | Inside width (mm) B | Roller Dia. (mm) C | Pin Dia. (nominal) D | Step Bush Bore D1 | Inner Plate height E | thick F | Outer Plate height G | thick H | Breaking Load (kN) |
|-----------------|--------------------|---------------------------|--------------------------|----------------------------|-------------------------|----------------------------|------------|----------------------------|------------|--------------------------|
| E 501 | 135.46 | 31.00 | 47.95 | 29.74 | n/a | 70.00 | 6.70 | 63.00 | 6.70 | 263 |
| E 502 | 80.00 | 25.40 | 48.21 | 30.11 | 22.06 | 70.00 | 6.35 | 70.00 | 6.35 | 245 |
| E 503 | 80.00 | 19.56 | 48.21 | 30.11 | 22.06 | 60.00 | 4.95 | 60.00 | 4.95 | 157 |
| E 504 | 100.00 | 25.70 | 25.35 | 14.62 | n/a | 40.25 | 5.95 | 40.25 | 4.90 | 205 |
| E 505 | 101.25 | 45.75 | 48.21 | 29.24 | n/a | 70.00 | 12.15 | 70.00 | 10.15 | 700 |
| E 506 | 101.25 | 25.40 | 39.97 | 22.00 | n/a | 45.25 | 5.95 | 45.25 | 5.95 | 202 |
| E 507 | 101.25 | 29.75 | 39.95 | 22.00 | n/a | 60.40 | 6.95 | 60.40 | 6.95 | 283 |
| E 508 | 101.25 | 29.75 | 39.95 | 22.00 | n/a | 60.40 | 6.95 | 60.40 | 6.95 | 283 |
| E 509 | 100.00 | 25.40 | 25.35 | 14.62 | n/a | 37.75 | 5.95 | 37.75 | 4.95 | 202 |
| E 510 | 135.45 | 33.07 | 85.59 | 42.67 | 31.97 | 88.9 | 9.52 | 76.2 | 9.52 | 343 |
| E 511 | 135.45 | 33.07 | 85.59 | 44.25 | 31.97 | 95.25 | 6.35 | 76.2 | 6.35 | 267 |
| E 512 | 135.45 | 32.84 | 38.04 | 28.19 | 20.70 | 60.32 | 9.52 | 60.32 | 9.525 | 321 |
| E 513 | 135.45 | 32.53 | 34.87 | 44.25 | 31.97 | 107.95 | 6.35 | 95.25 | 6.35 | 267 |
| E 514 | 133.33 | 34.80 | 64.00 | 31.98 | n/a | 80.50 | 7.00 | 80.50 | 6.00 | 340 |

E 600 SERIES

Heavy duty public service escalators supplied as 'ladders' / axle assemblies.

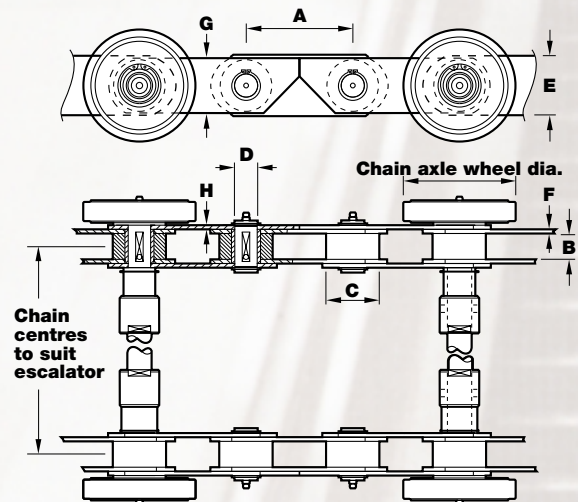

HEAVY DUTY LADDER TYPE Nominal Dimensions (mm)

| Series E 600 | Pitch (mm) A | Inside width (mm) B | Roller Dia. (mm) C | Pin Dia. (nominal) D | Chain axle Dia. | Inner Plate height E | thick F | Outer Plate height G | thick H | Breaking Load (kN) |
|-----------------|--------------------|---------------------------|--------------------------|----------------------------|--------------------|----------------------------|------------|----------------------------|------------|--------------------------|
| E 602 | 135.46 | 29.81 | 69.94 | 39.97 | 22.21 | 90.50 | 6.05 | 80.50 | 6.05 | 396 |
| E 603 | 135.46 | 48.20 | 69.94 | 41.97 | 22.21 | 115.50 | 6.05 | 105.50 | 6.05 | 596 |
| E 606 | 135.45 | 29.69 | 70.10 | 39.95 | 29.97 | 90.50 | 6.04 | 80.51 | 6.04 | 360 |
| E 607 | 135.45 | 30.40 | 70.10 | 41.96 | 29.97 | 115.49 | 6.04 | 105.51 | 6.04 | 515 |

Escalator Industry - Renolube Step Chain

RENOLD

RENOLUBE - ESCALATOR STEP CHAIN

Renolube Escalator Chain has been developed as a result of extensive prototype testing in arduous applications to exceed the industry's ever increasing demand for lower service costs and longer lifetime operation.

With over 50 years' experience, Renold is recognised as one of the world's leading manufacturers of escalator chains.

The Renolube polymer bush, in conjunction with a specially designed bearing pin, has been formulated to ensure maximum lifetime operation.

The principle advantages of Renolube are:-

- Substantially lower life cycle costs with development and field tests indicating a life in excess of 20 years.
- Cleaner environment because of reduced free grease and oil lubrication.
- Significantly lower service costs, in that periodic grease and oil lubrication is not required.
- Stable and predictable wear rates are a particular feature of Renolube when compared to conventionally oiled and greased chains, which can be prone to random failure.

ENDURANCE

Renolube Escalator Chain in the public service environment has proven to be extremely wear resistant. Installation of the Renolube Escalator Chain provides lifetime confidence with an extended chain design life.

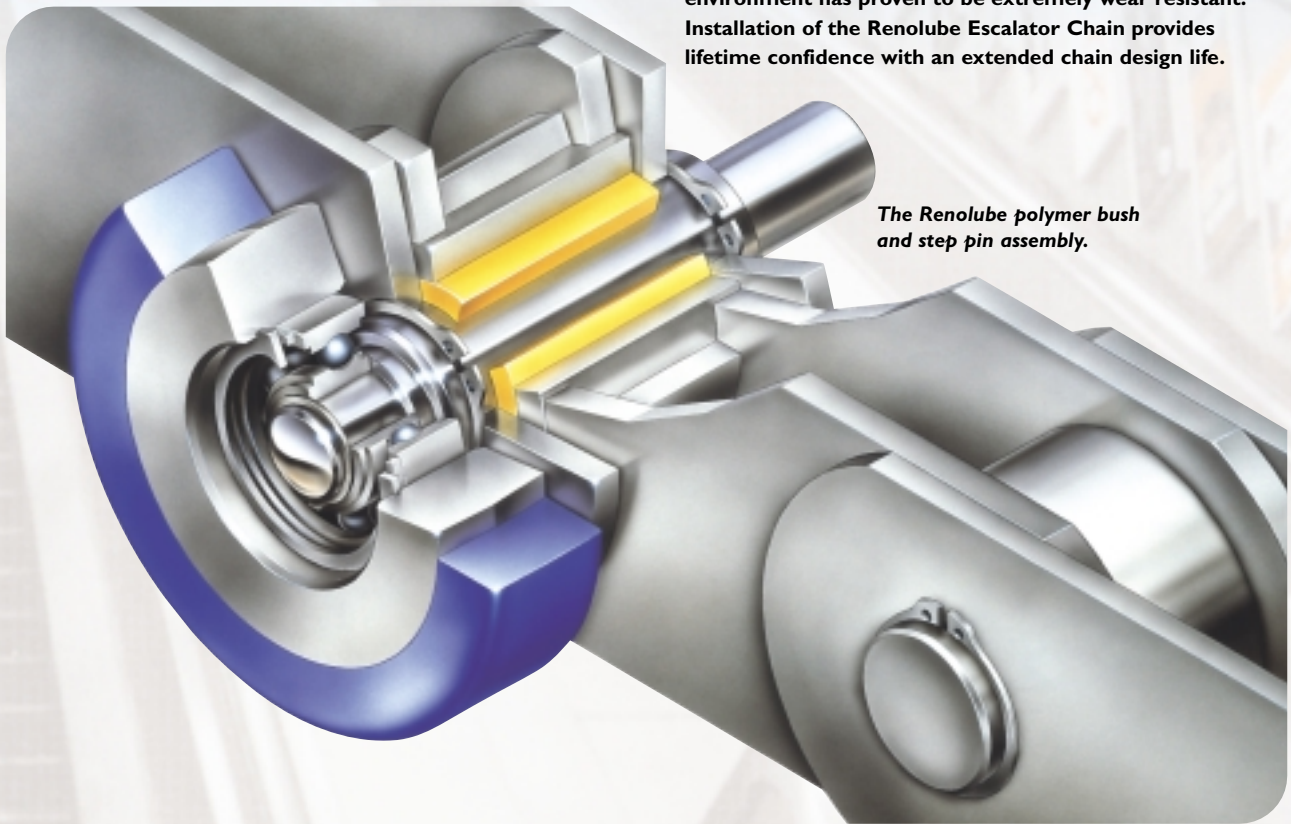

The Renolube polymer bush and step pin assembly.

TYPICAL WEAR / LIFE

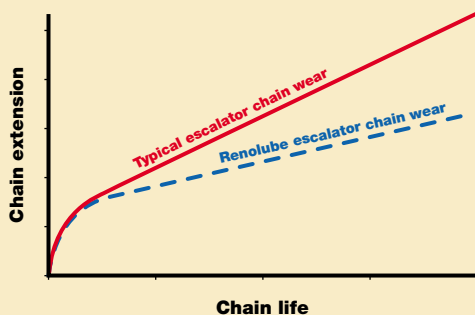

ECONOMY

Renolube offers a fully cost effective solution when replacing grease lubrication systems, thus considerably reducing expensive maintenance and life cycle costs.

ENVIRONMENT AND SAFETY

The elimination of copious amounts of lubricating oils and grease creates a cleaner and safer environment, thereby reducing fire risk.

Renold Drive Packages

RENOLD - DRIVE PACKAGES

For over 100 years Renold have been leaders in the design and manufacture of innovative Power Transmission products and solutions.

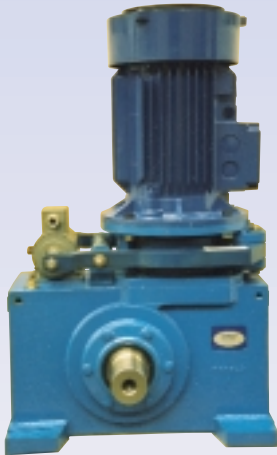
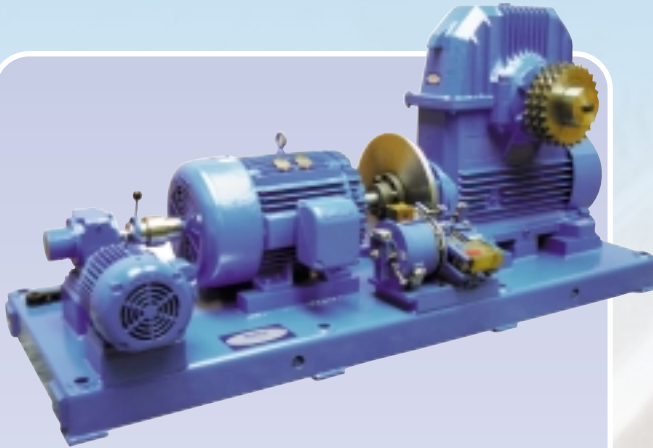

Renold has developed considerable expertise in both engineering solutions for escalator and elevator applications on new construction and modernisation of existing installations.

- Renold has the unique capability to not only offer a comprehensive standard range of escalator and elevator drive packages, but also application specific units including both adapted 'standards' and special assemblies.
- Our unique design and manufacturing ability, together with full project management ensures every customer receives the most appropriate solution for their application needs.

Renold also offers a hand winding unit solution for both geared and gearless machines.

- The hand wind drive package can be fitted as a conversion for gearless machines where manual handwind option is required, or on geared traction machines, where a simple handwheel would not be suitable due to high loads.
- The hand wind package comprises of handwheel, gear unit and disconnecting clutch supplied as one package suitable for foot or direct flange mounting.

All Renold lift packages conform to ASME.A17.1 section 208.

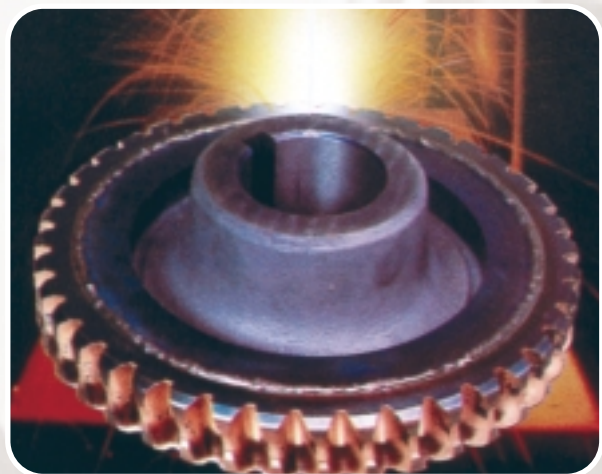

- Rims electron beam fused to centres for strength.
- 100 year gear design and capability.
- Gears and gear sets computer designed.
- BS EN ISO 9001:1994 approved.



TW Series wormgear units used 14" to 28" centre distance, AC motor, brake coupling and brake with final chain drive. Unit shown being load tested at Renold Gears.



Special wormgear unit manufactured with 3 sizes, using 4", 6" and 8" centre distance wormgears. Unit supplied with vertical AC motor, brake coupling and calliper brake between motor and gear unit.

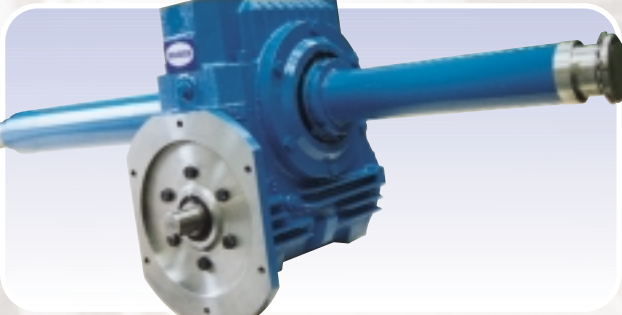

Unit used is standard 6" centres shaft mounted wormgear unit, but modified with large motor flange at input and extended output shaft. Unit fitted in the middle of the step - chain headshaft wheels



Special wormgear unit manufactured using 8" centre distance wormgears, vertical worm enabling customer to provide his own motor and brake.

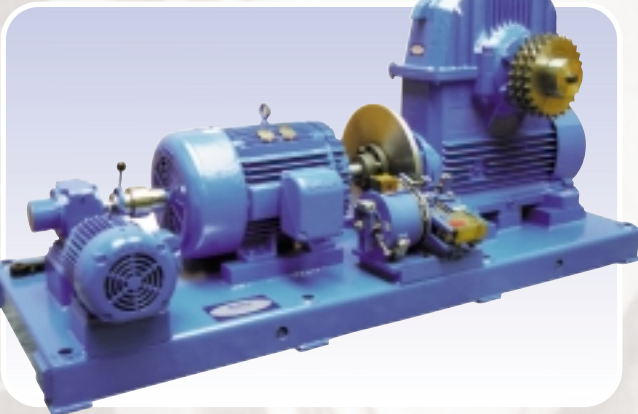

TW Series Wormgear units 12" to 20" centre distance with single and two speed motors. Electronic speed control and soft start device used, disc brake and slow speed auxiliary drive unit with disconnecting clutch.

Escalator Drive Applications

New York City Transit Escalator Drives

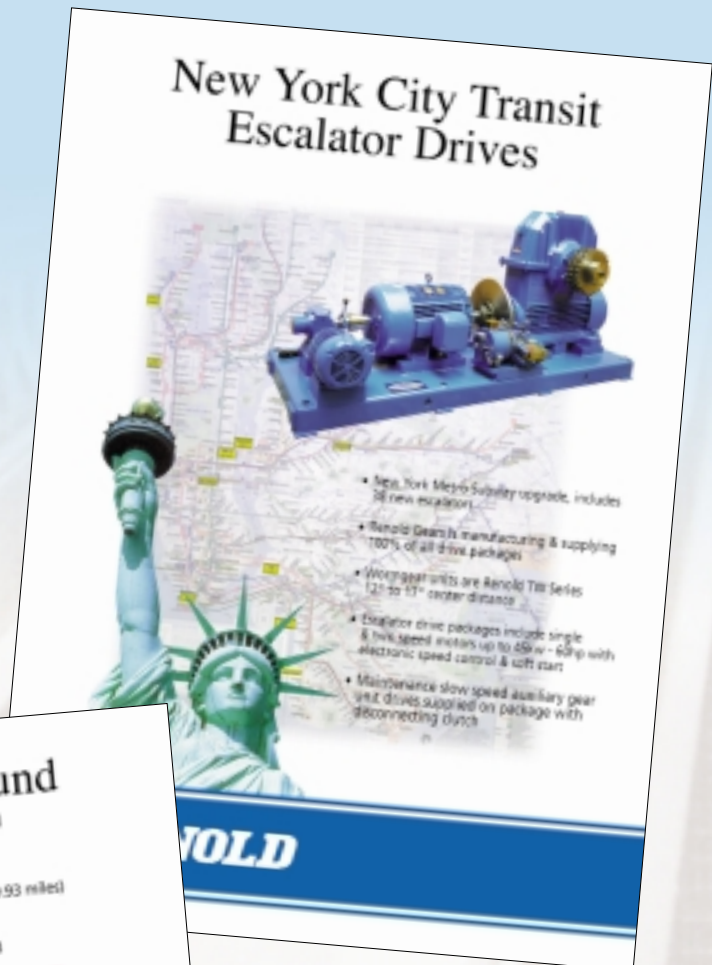

- New York Metro Subway upgrade, includes 38 new escalators
- Renold Gears is manufacturing & supplying 100% of all drive packages
- Wormgear units are Renold TW Series 12" to 17" center distance
- Escalator drive packages include single & two speed motors up to 85kw - 60hp with electronic speed control & soft start
- Maintenance slow speed auxiliary gear unit drives supplied on package with disconnecting clutch

RENOLD

London Underground Jubilee Line Extension

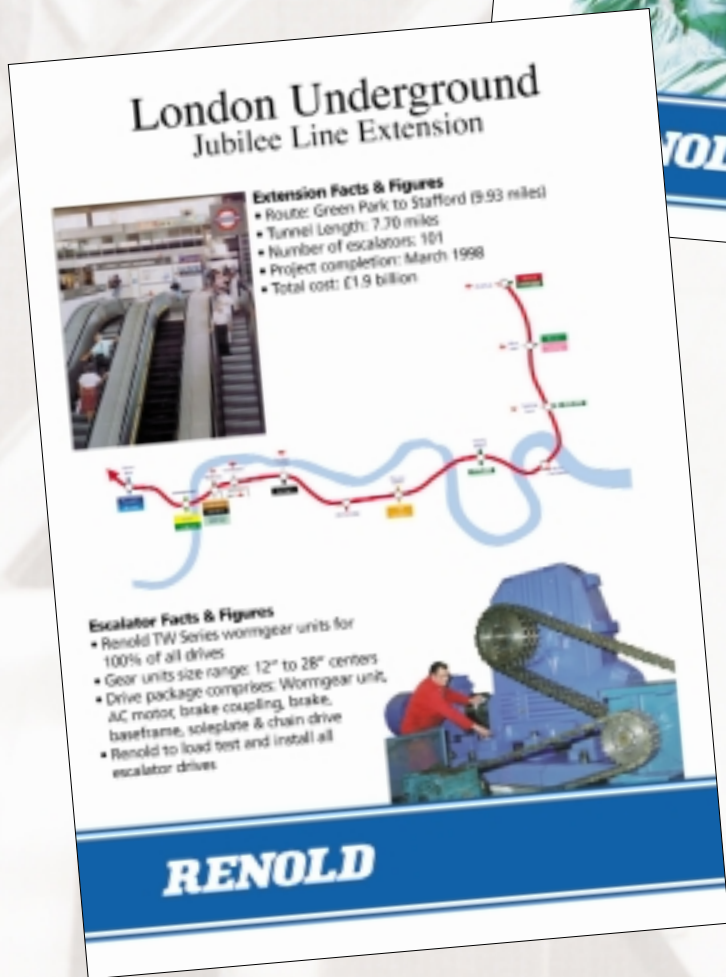

Extension Facts & Figures

- Route: Green Park to Stafford (9.93 miles)
- Tunnel Length: 7.70 miles
- Number of escalators: 181
- Project completion: March 1998
- Total cost: £1.9 billion

Escalator Facts & Figures

- Renold TW Series wormgear units for 100% of all drives
- Gear units size range: 12" to 28" centers
- Drive package comprises: Wormgear unit, AC motor, brake coupling, brake, baseframe, soleplate & chain drive
- Renold to load test and install all escalator drives

RENOLD



Compact Drive Overhung



Medium Capacity Standard Drive



Large Capacity Combination Baseplate and Drive

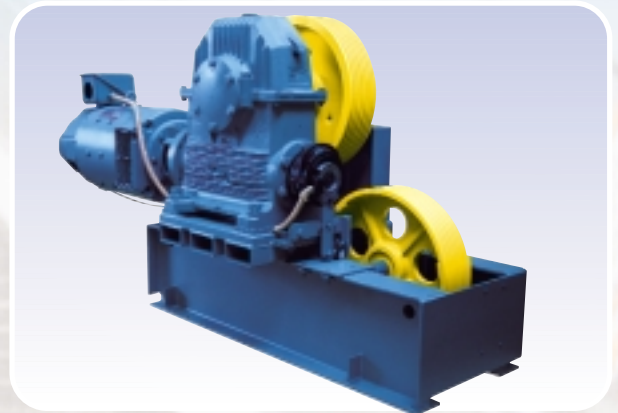

Standard Lift Gear Package with Bespoke Baseplate and Diverter

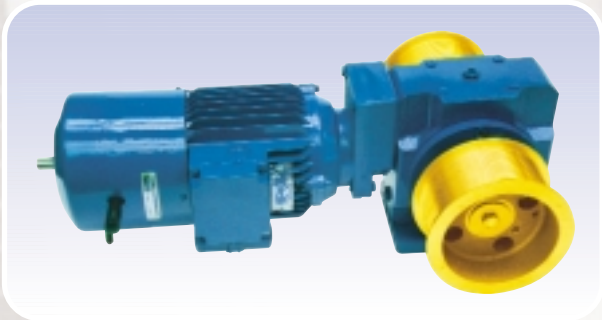

Small Capacity Overhead Drive



Medium Capacity Special Drive Package



Standard and custom made special gear sets for elevator and escalator drive systems



Hand Winding Drive Solution for Both Geared and Gearless Machines

RENOLD



AUSTRALIA

Melbourne (Victoria),
Tel + 61(0) 3 9262 3333 Fax + 61(0) 3 9561 8561
e-mail: melsmg@renold.com.au
also at: Sydney, Brisbane, Adelaide, Perth,
Newcastle, Wollongong, Townsville

AUSTRIA

Vienna,
Tel + 43 (0) 1 330 3484 Fax + 43 (0) 1 330 3484-5
also at: Kiskörös (Hungary),
Jaroslavice (Czech Republic)
e-mail: office@renold.at

BELGIUM

Brussels,
Tel + 32 (0) 2 201 1262 Fax + 32 (0) 2 203 2210
e-mail: info@renold.be

CANADA

Brantford (Ontario),
Tel + 1 519 756 6118 Fax + 1 519 756 1767
e-mail: inquiry@renoldcanada.com
also at: Montreal

CHINA

Shanghai,
Tel +86 21 5046 2696 Fax +86 21 5046 2695
e-mail: sales@renold.cn

DENMARK

Brøndby (Copenhagen),
Tel + 45 43 45 26 11 Fax + 45 43 45 65 92
e-mail: info@renold.dk

FRANCE

Seclin,
Tel + 33 (0) 320 16 29 29 Fax + 33 (0) 320 16 29 00
e-mail: contact@brampton-renold.com

GERMANY

Einbeck,
Tel + 49 (0) 5562 81248 Fax + 49 (0) 5562 81130
e-mail: info@arnold-und-stolzenberg.de
also at: Hamburg, Bielefeld, Düsseldorf, Frankfurt,
Kornwestheim, Berlin

MALAYSIA

Petaling Jaya,
Tel +60 3-5191 9880 Fax +60 3-5191 9881
e-mail: malaysia@renold.com
also at: Johor Bharu, Ipoh, Butterworth

NETHERLANDS

Amsterdam,
Tel + 31 (0)20 6146661 Fax + 31 (0)20 6146391
e-mail: info@renold.nl

NEW ZEALAND

Auckland,
Tel + 64 9828 5018 Fax + 64 9828 5019
e-mail: aksales@renold.co.nz
also at: Christchurch

SINGAPORE

Singapore,
Tel + 65 760 2422 Fax + 65 760 1507
e-mail: renoldsp@singnet.com.sg

SOUTH AFRICA

Benoni (Johannesburg),
Tel + 27 11 747 9500 Fax + 27 11 747 9505
e-mail: sales@renoldcrofts.co.za
also at: Witbank, Richards Bay, Port Elizabeth,
Cape Town

SWEDEN

Brøndby (Copenhagen),
Tel + 45 43 45 26 11 Fax + 45 43 45 65 92
e-mail: info@renold.dk

SWITZERLAND

Dübendorf (Zürich),
Tel + 41 (1) 824 8484 Fax + 41 (1) 824 8411
e-mail: info@renold-gmbh.ch
also at: Crissier (Lausanne)

UK

Burton upon Trent,
Tel + 44 (0) 1283 512940 Fax + 44 (0) 1283 512628
e-mail: ukchain@renold.com

USA

Renold Jeffrey
2305 Global Way, Hebron, KY 41048
Tel (800) 850-8141
e-mail: information@renoldusa.com
Jeffrey Chain Corp.
2307 Maden Drive, Morristown, TN 37813
Tel +1 800 251 9012 Fax +1 423 581 2399
e-mail: sales@jeffreychain.com

For other country distributors please contact Renold UK.

Whilst all reasonable care in compiling the information contained in this brochure is taken, no responsibility is accepted for printing errors. All information contained in this brochure is subject to change after the date of publication.

© Renold Power Transmission Limited 2004.

Ref: REN28 / ENG / 07.04